



# Product Guide

## LA Series...

## LA Series

*Large A-Coils*

- Vertical coils designed for large tonnage applications (6-10 Ton)
- Upflow and downflow capable
- Embossed, galvanized steel cabinets
- Corrosion-resistant aluminum drain pans
- Available with R-410A or R-22 TXV's factory installed
- For A/C and heat pump applications





Made in USA

# Product Nomenclature

LA 6 1 AC \_

### Large Capacity Coil

LA: "A" Coil

LH: Horizontal Coil

### Refrigerant

Blank: R-22

4: R-410A

### Tonnage

### Application

AC: Air Conditioning

AC/HP: Air Conditioning & \*Heat Pump

### Number of Circuits

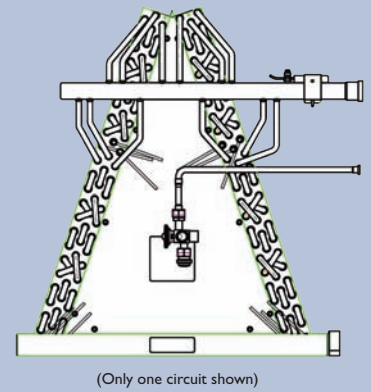
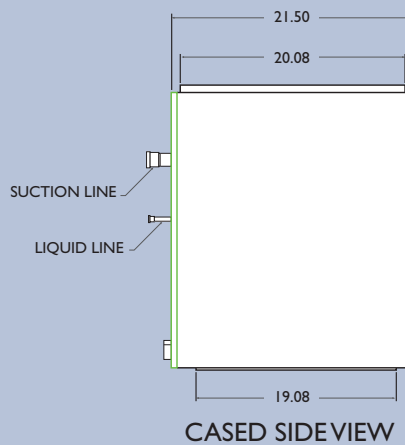
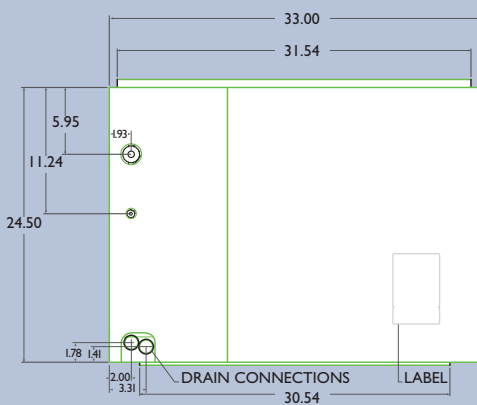

Proudly distributed by:

2175 West Park Place Boulevard  
Stone Mountain, Georgia 30087  
www.adpnow.com



ISO 9001:2008  
—Registered Quality System—