

Steam-Rated Commercial Grade Condensate Pumps

Model SC-1A Series Pumps

BENEFITS

- 💧 **Rated for 2,000 EDR; 480,000 BTU**
- 💧 **Vapor sealed, 4 gallon cast aluminum reservoir**
- 💧 **Steam rated for 2,000 EDR, 480,000 BTU**
- 💧 **Max temperature to 212°**
- 💧 **Stainless steel float**



Hartell's steam-rated condensate pump is designed expressly for the automatic return of condensate to a collection point where radiation has been added to existing systems below the return.

FEATURES

- 💧 **1/2 hp, 3,400 rpm motor**
- 💧 **Inlet: 1-1/2" FNPT, Outlet: 3/4" FNPT**
- 💧 **Integral junction box**
- 💧 **Usable lifts over 40 ft**
- 💧 **Dual voltage motor**
- 💧 **Heavy duty design for industrial applications**



Model	Part No.	Aux. Switch	hp@rpm	Voltage	Full Load Amps	Performance						Shut off	Dimensions			
						Lift/Feet	6'	12'	18'	24'	36'		45'	Width	Length	Height
SC-1A	851068	N	1/2@ 3450	115/230	7.46/3.7	Gallons/hr	4200	3780	3420	2820	1800	-	12"	12"	19"	45lbs
SC-1AX	851123	Y				Lift/Meter	1.8m	3.6m	5.5m	7.3m	10.9m	13.7m				
						Liters/hr	15898	14308	12946	10674	6813	-				

Steam-Rated Commercial Grade Condensate Pumps

Model SC-1A Series Pumps

DATA SHEET

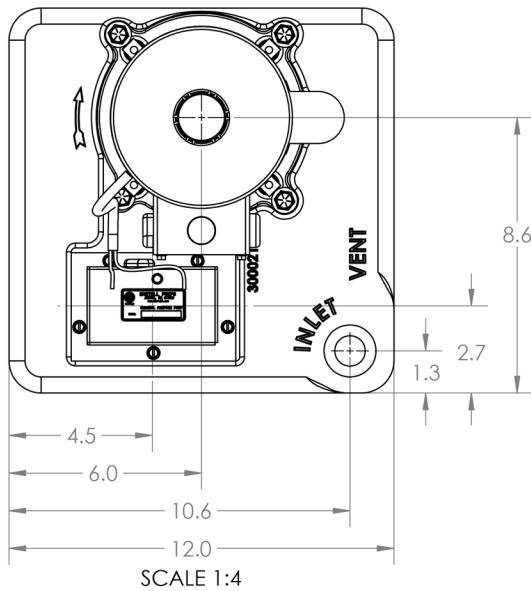

TOP VIEW

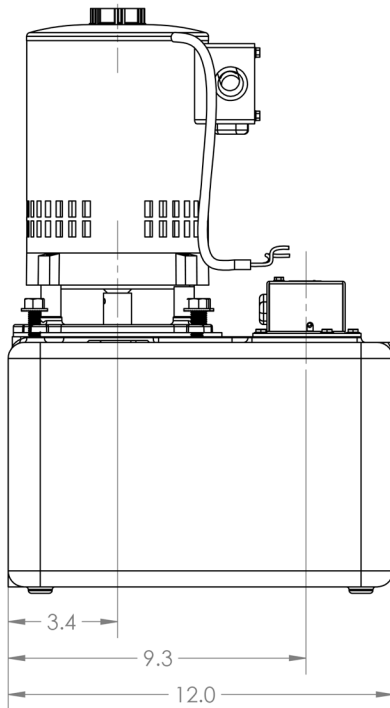
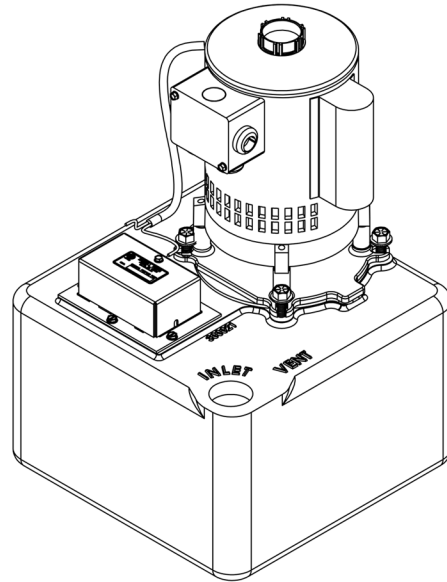

SIDE VIEW

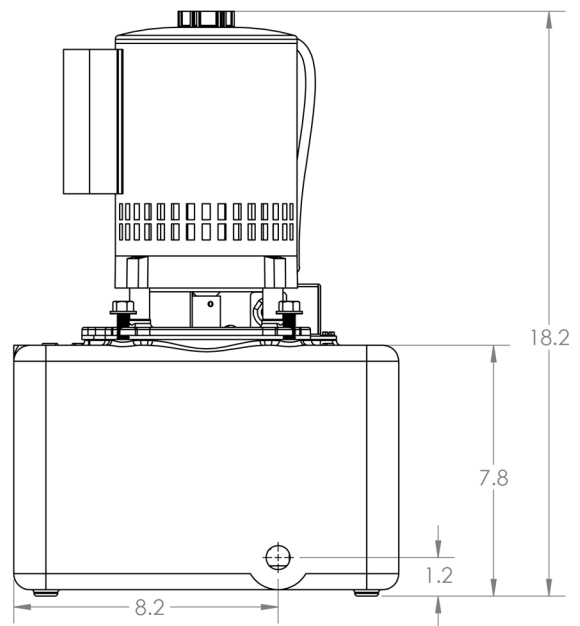

DISCHARGE END VIEW